

Heritage Range Cooker

DUETTE STANDARD & DUETTE GRANDE

INSTALLATION & USER MANUAL

OIL FIRED



Please read this manual BEFORE installing, commissioning, servicing, or using a HERITAGE RANGE COOKER

CONTENTS

DUETTE STANDARD & DUETTE GRANDE OIL-FIRED

- 1) Contents
- 2) Introduction
- 3) Safety notices & Appropriate Bylaws/regulations
- 4) Technical Specification
- 5) Appliance Details
- 6) Delivery/Transport
- 7) Physical Dimensions

INSTALLATION

- 8) Site & System Considerations
- 9) Heating System Requirements
- 10) Heating System Schematic Layout
- 11) Flue System
- 12-12A) Flues – schematic
- 13) Low Level Flues – schematic
- 14-15) Oil Supply Considerations

ELECTRICS

- 16) Electrical System
- 17) Internal Wiring Control Panel
- 18) System Wiring (schematic) – Conventional Flue
- 19) System Wiring (schematic) – Fan Flue
- 20) 10-Way Connector Explanation Chart

COMMISSIONING & SERVICING

- 21-22) Commissioning Procedures
- 23-24) Fault Finding
- 25) Servicing & Maintenance
- 26) Heritage Service Sheet

USER SECTION

- 27-28) Operating Instructions
- 29) Control panel
- 30) Looking After Your Heritage
- 31) Installer Details & Contact Telephone Number
- 32) Notes

**YOUR HERITAGE RANGE COOKER IS MADE IN THE E.U. OF
MATERIALS AND COMPONENTS SOURCED WHOLLY IN THE E.U.**

Serial number of your range:

Please quote above number when in future correspondence with your dealer.

INTRODUCTION

Congratulations on purchasing a Heritage Duette Range Cooker.

The Heritage Duette Range Cooker is built to last from the highest quality materials. Its innovative design and selection of excellent components makes it a pleasure to use and maintain. Once installed, operated and maintained in accordance with the procedures described in this manual, you should experience many years of faithful service from your Heritage.

COMMISSIONING OF THIS APPLIANCE MUST ONLY BE CARRIED OUT BY A COMPETENT OFTEC ENGINEER

It is imperative that the appliance be installed in compliance with all relevant national and regional regulations.

The proposed system must be designed or approved by a competent heating and plumbing engineer.

The Manufacturers/Suppliers of Heritage Range Cookers will not accept liability for damages resulting from incorrect installation/commissioning or misuse of appliance.

WARRANTY APPLIES TO HERITAGE PRODUCTS SOLD IN UK AND EIRE ONLY.

FOR GUARANTEE/WARRANTY FOR PRODUCTS SOLD OUTSIDE OF THESE AREAS PLEASE CONTACT THE MANUFACTURER FOR WRITTEN AUTHORISATION.

THIS PRODUCT AND MANUAL RELATE TO NORMAL DOMESTIC USE ONLY

FOR ALL **COMMERCIAL INSTALLATIONS AND USES** A SITE SURVEY AND WRITTEN APPROVAL FROM OUR TECHNICAL DEPARTMENT IS REQUIRED. THE SERVICING/MAINTENANCE SCHEDULE WOULD NEED TO REFLECT THE LEVEL OF USE OF THE APPLIANCE IN A COMMERCIAL ENVIRONMENT.

SAFETY FIRST

This is a heating appliance, and by definition it becomes hot when in service.

Please keep young children and pets at a safe distance.

Do not use a ceiling mounted clothes dryer in the vicinity of the appliance and never leave any combustible materials so close to the unit that they may present a fire hazard. (This includes leaving towels on the handrail, which can be dangerous).

Never leave pots or pans unattended on the Heritage Range. Especially: chip pans, frying pans or similar utensils should be continuously attended for your safety and the protection of your cooker.

DELIVERY/HANDLING OF COOKER - Please see page 6

IMPORTANT

CONTROL OF SUBSTANCES HARMFUL TO HEALTH (COSHH)

The installer is responsible to ensure that persons involved in the installation are provided with and make use of personal protective clothing when handling materials known to be injurious to health and safety.

- ❑ Ceramic materials: Wear facemask and gloves. Avoid contact with eyes, skin and throat. Dispose of waste safely
- ❑ Fuels: Wear gloves - avoid ignition sources. - DO NOT DISPOSE OF WASTE FUEL VIA DOMESTIC WASTE WATER COURSES
- ❑ Fire cement: Wear gloves - wash hands

Always work in adequately ventilated areas and allow enough space for access to appliance

SAFETY NOTICES AND RELEVANT REGULATIONS

The installation must comply with the following regulations where appropriate

- BS4814 Sealed Systems
- BS5449 Forced Circulation Hot Water Central Heating System for Domestic Installation
- BS7074 Parts 1 & 2 Hot Water Supply
- The Building Regulations: - Part J England and Wales - Part F section III Scotland - Part L Northern Ireland - Part J Ireland.
- BS7593 Treatment of Water in Domestic Hot Water Systems
- BS5440 Parts 1 & 2 Installation of Flues and Ventilation
- D.M.2. Installation in Timber Framed Buildings
- Safety Document 635 The Electricity at Work Regulations
- BS7671 Requirements for Electrical Regulations
- REC Rules regarding PME Earthing (where applicable)

Heritage Cookers comply with the following regulations: -

- Section 10 of the Consumer Protection Act 1987
- Oftec requirements
- Health and Safety at Work Act
- B.E.D. Boiler Efficiency Directive. *

WARNING: CORRECT EARTHING MUST BE PROVIDED FOR THIS APPLIANCE

If in doubt seek advice from a qualified electrical engineer.

Prior to carrying out any work on the appliance switch off at the mains and remove the fuses from the fused spur outlet and from the user control panel. Replace when works are completed.

Always ensure appliance is 'electrically dead' prior to working on the electrics.

*** Heritage Central Heating Cooker Boilers meet the requirements of Boiler Efficiency Directive 1993 (for boilers fired with liquid or gaseous fuels) tested by Notified Body 0087.**

TECHNICAL SPECIFICATION

Appliance type -	Combination Central Heating boiler, cooker & space heater
Burner system -	Sterling 40/50 on/off pressure jet x 2
Fuel -	28 –35 sec Kerosene
Country of Designation -	I.E. & U.K.
Mains supply -	230 Vac @ 50HZ from a dedicated fused spur
Fuse rating -	3A
I.P Protection -	20
Load (Running) -	130W (Nominal)
Oil pump working pressure -	NB. See data plate for actual model/burner.
Flue diameter/spigot -	125mm/5", with flue test points for each burner
Boiler construction -	5mm mild steel
Appliance total energy output -	40,000(11.7kw) to 140,000 (41kw) BTU per hr
Design ΔT -	11°C
Maximum working pressure of boiler -	1.5 bar
Safety Thermostat Temperature -	96° C Boiler
Test pressure of boiler -	4 bar
Fluid frictional losses -	minimal
Flue Draught -	0.04" to 0.08" WG measured at test point. NB.Grande model may require higher draught.
Installation requirements -	Must be installed in accordance with good Practice and as laid down by all relevant codes of practice by suitably qualified installers. NB: See Instructions in this manual.
Boiler tappings -	
40-80,000 BTU models -	28mm 1" BSP – Flow <u>and</u> Return (NB. Do <u>not</u> use reducing fittings on the cooker boiler tappings – see page 9)
100-140,000 BTU models -	35mm 1¼" BSP – Flow <u>and</u> Return (NB. Do <u>not</u> use reducing fittings on the cooker boiler tappings – see page 9) Rear outlet only for Grande models. (NB: Pipe sizes must be appropriate for system)
Air to burner -	Adequate combustion air must be freely available and unrestricted at all times.
Permanent supply connections	NB: It is strongly recommended that an external air supply be ducted directly to burner inlet connections provided. Please ask for technical advice if in doubt.

APPLIANCE DETAILS

OVERALL SIZE -	HEIGHT (to hob)	910mm (36")
	WIDTH (Standard models)	975mm (38½")
	(Grande models)	1450mm (57")
	DEPTH (to towel rail)	740mm (29")

HOTPLATES (steel) – 340mm diameter x 2
400mm x 340mm (Grande models)

OVENS -	HEIGHT	270mm (10¾")
	DEPTH	500mm (19¾")
	WIDTH	345mm (13¾")

(Roasting & Warming ovens are of equal size)

Ovens are of 5mm thick steel construction, vented into the flue system & have 3 rail heights each. Oven racks are of chromed steel.

The internal flue passages are of continuous welded fabrication.

WEIGHT -	Standard models - approx 500kg (packaging not included)
	Grande models - approx 750kg (packaging not included)

CONSTRUCTION - Cast iron vitreous enamelled doors and lids.
Vitreous enamelled steel top plate & front plate.
Top plate enamel – acid resistant.
All trim is Nickel plated steel or solid brass
Fascia & towel rail are stainless steel or brass

Appliance controls.

The main roasting oven has the oven control thermostat positioned in the middle left hand side retained with stainless steel fixings. The warming oven has the oven high limit safety stat positioned in the top left corner, encased within a stainless steel pocket. The boiler is controlled by a control stat and a high limit stat. Both cooker and boiler limit stats are manual reset, and when activated they illuminate on the control panel where you will also find the reset buttons.

The two burners can operate independently or at the same time. The appliance is fitted with a programmer, allowing for timing of hot water and cooking. A programmable room thermostat wired externally operates the central heating.

The ovens are heat retentive – requiring the burner to fire for approximately 15 – 20% of the time – therefore, good fuel economy can easily be achieved by the Duette & Grande version. The Grande version is powered by similar fuel input as the standard Duette and takes 35-40 minutes to achieve roasting temperature in the top right oven (the control oven) from a cold start, with the baffle in the open position. When the baffle is closed the Grande will perform as a Standard Duette, with a small heat leak to left-hand ovens.

NB. For even oven temperature it is necessary to allow the ovens to stabilize after reaching the desired temperature. A Cold shelf has been provided to assist control.

Please see supplied cooking hints.

DELIVERY & TRANSPORT

Your Heritage Range is a robust, solid and heavy appliance. When attempting to move/transport please plan properly. - Weight approx. 500 Kg (Standard models), 750kg (Grande models).

EXTERNAL - IN VEHICLE - Ensure unit is securely held by ropes and handled carefully by qualified personnel.

INTERNAL

Remove all breakables, rugs and other obstructions from your path - If a doorway is narrow, unhinge door, it will make entry easier, avoiding damage to appliance, property and most importantly to persons.

The plinth on the appliance is flat based and strong enough to permit the unit to be moved on rollers. Remove the doors from the unit to provide handholds.

DO NOT

- Lift the appliance by the top plate or move it by the top plate.
- Use objects to lever or move the appliance, which may result in damage to it, property or persons.
- Risk moving appliance over difficult terrain, down steps or up steps without adequate manpower and proper precautions.

NB: Your supplier can with sufficient notice provide an authorised Engineer to attend site, strip the appliance and rebuild in situ. The charge for this specialist service is dependent on conditions and distances involved.

DO NOT STRIP & REBUILD THE COOKER YOURSELF. THIS WILL INVALIDATE YOUR WARRANTY.

PHYSICAL DIMENSIONS

Standard model

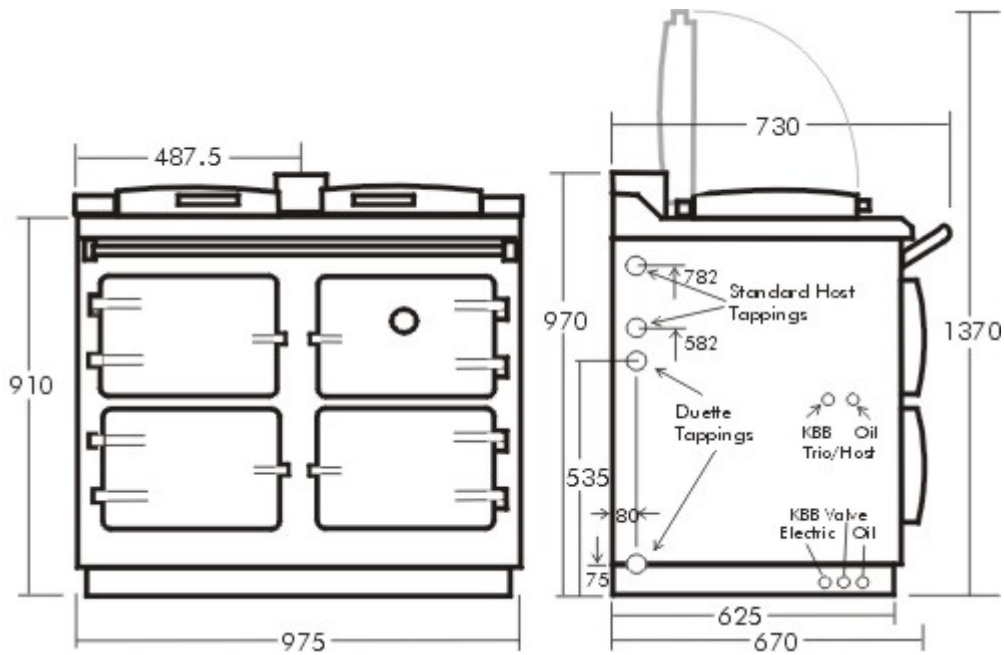

Grande model

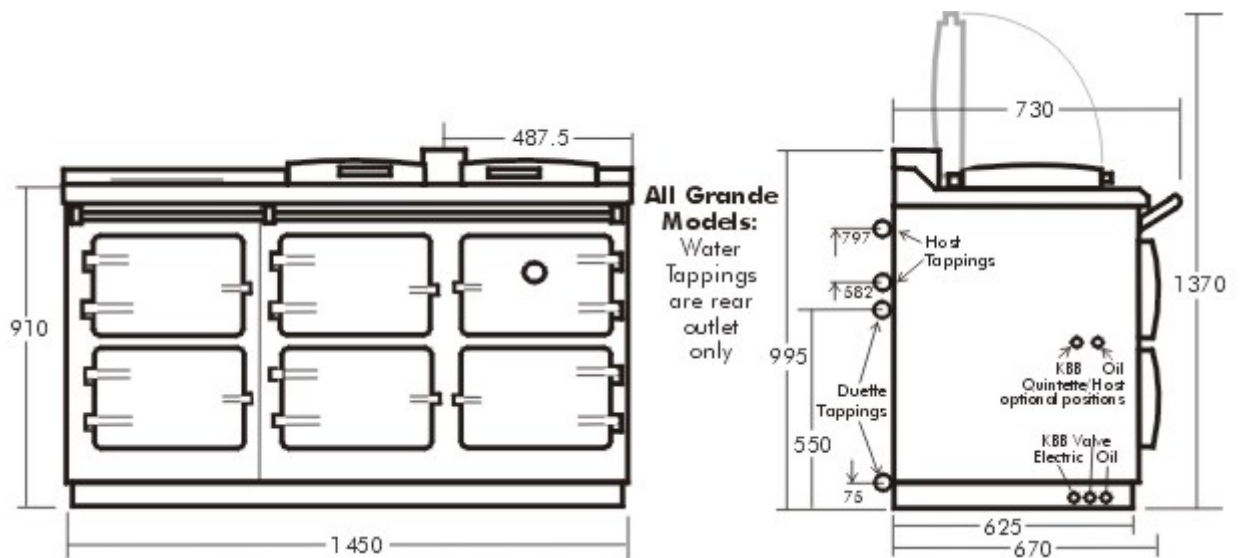

The air to burner connections can be modified to enter into appliance in other configurations. The site survey will advise the best option and can be adapted at the time of manufacture. Standard dimensions are 180mm & 300mm to centres.

SITE AND SYSTEM CONSIDERATIONS

General Considerations

- 1) Adequate space for appliance, especially access for service and maintenance purposes.
- 2) Provision of a satisfactory flue/chimney/cowl.
- 3) A solid non-combustible hearth capable of supporting the appliance.
- 4) Non-combustible walls/surfaces adjacent to appliance
- 5) Access to an outside wall or some other means of supplying unrestricted air to the burner.
- 6) If positioned within an inglenook, allow a minimum of 1.5 meters height clearance for comfortable operation of cooker.
- 7) Allow 25mm clearance to kitchen units & 10mm to worktops (laminated & wooden); 3mm for granite & composite stone.
- 8) The appliance must NOT be built in. The top plate and front plate especially must be removable for maintenance. Do not tile onto top plate or trap top plate between worktops.

Heating System Consideration

The design and installation of the heating system must comply with all the regulations and statutes cited on page 2 of this manual. The Heritage Duette should be installed in a fully pumped system complying with the design requirements of Honeywell S-plan or equivalent. Should the installation be into an open-vented system it will function efficiently provided the original system has been appraised and modified by a competent installation engineer.

Reference should be made to the schematic illustration found on page 10

For installation of the appliance into an existing heating system it is essential to have a qualified heating engineer survey the system for compatibility and suitability. **PLEASE DO NOT ASSUME THAT BECAUSE THE EXISTING SYSTEM WORKED WITH ANOTHER APPLIANCE THAT IT WILL WORK WITH A NEW APPLIANCE - SYSTEMS MUST MEET THE DESIGN CRITERIA FOR THE NEW APPLIANCE.**

This survey must include: -

- 1) Design & Type of system
- 2) Radiator size & condition
- 3) Pipe work/fittings - size & condition
- 4) Ancillaries - pump, expansion vessel, tanks etc.
- 5) Cylinder - size & condition
- 6) Installation quality
- 7) Safety of installation

Heat to the room (space heating)

The Heritage Duette Range is extremely well insulated, radiating between 3,000 - 7,000 BTU's (1 - 2kw) dependant on model, size and mode of use. This makes it ideal for summer use where the kitchen space is to be maintained cool. For additional space heating one can lift the lid domes, this has no detrimental affect on oven temperatures. In winter use we recommend use of a suitably sized radiator, to heat the room in which the appliance is situated, particularly in larger kitchens.

HEATING SYSTEM REQUIREMENTS

System Design

The Heritage Duette Range is designed to operate on a fully pumped system. It is preferred that the system should be pressurised (in the range of 0.5-1.5 bar).

CONTROLS

The Honeywell 'S' plan system will allow for satisfactory control of the installation, as per the wiring diagrams in this manual ('Y' plan not recommended)

THE HEATING CIRCUIT:

Must incorporate a differential automatic by-pass valve to meet current regulations. A heat-leak radiator can be fitted, if required.

PIPE SIZING

Primary pipes must be a minimum of 28mm diameter for 40,000 – 80,000 Btu models, and 35mm diameter for models of 100,000Btu and above. Larger diameter pipes may be necessary depending on the system design particularly with 100,000 Btu models and above.

NB. Do not use reducing fittings on cooker boiler tappings.

NB. Boilers must be permanently vented to prevent any air locks, which would reduce the boiler life.

The system must be fitted with drain off cocks at the lowest points and are to be readily accessible. See BS2879.

CYLINDER

A suitably insulated indirect cylinder of not less than 210 litres is recommended for optimum performance. A smaller cylinder is acceptable provided it supplies sufficient hot water for the property requirements.

The system must incorporate a 3 bar safety valve fitted to the flow pipe as close to the appliance as possible. Make certain that if the valve should discharge it will not cause personal injury or affect the electrical installation.

FROST STAT

It is advisable to fit a frost stat if the locality is subject to severe frosts or if the appliance or dwelling are going to be left unused for a period of time during the winter months.

CORROSION INHIBITOR

An inhibitor **MUST** be added to the water system after entire system has been flushed. If the system is later drained for any reason, inhibitor **MUST** again be added.

Please follow manufacturers instructions carefully or **YOUR GUARANTEE MAY BE INVALIDATED.**

HEATING SYSTEM SCHEMATIC LAYOUT

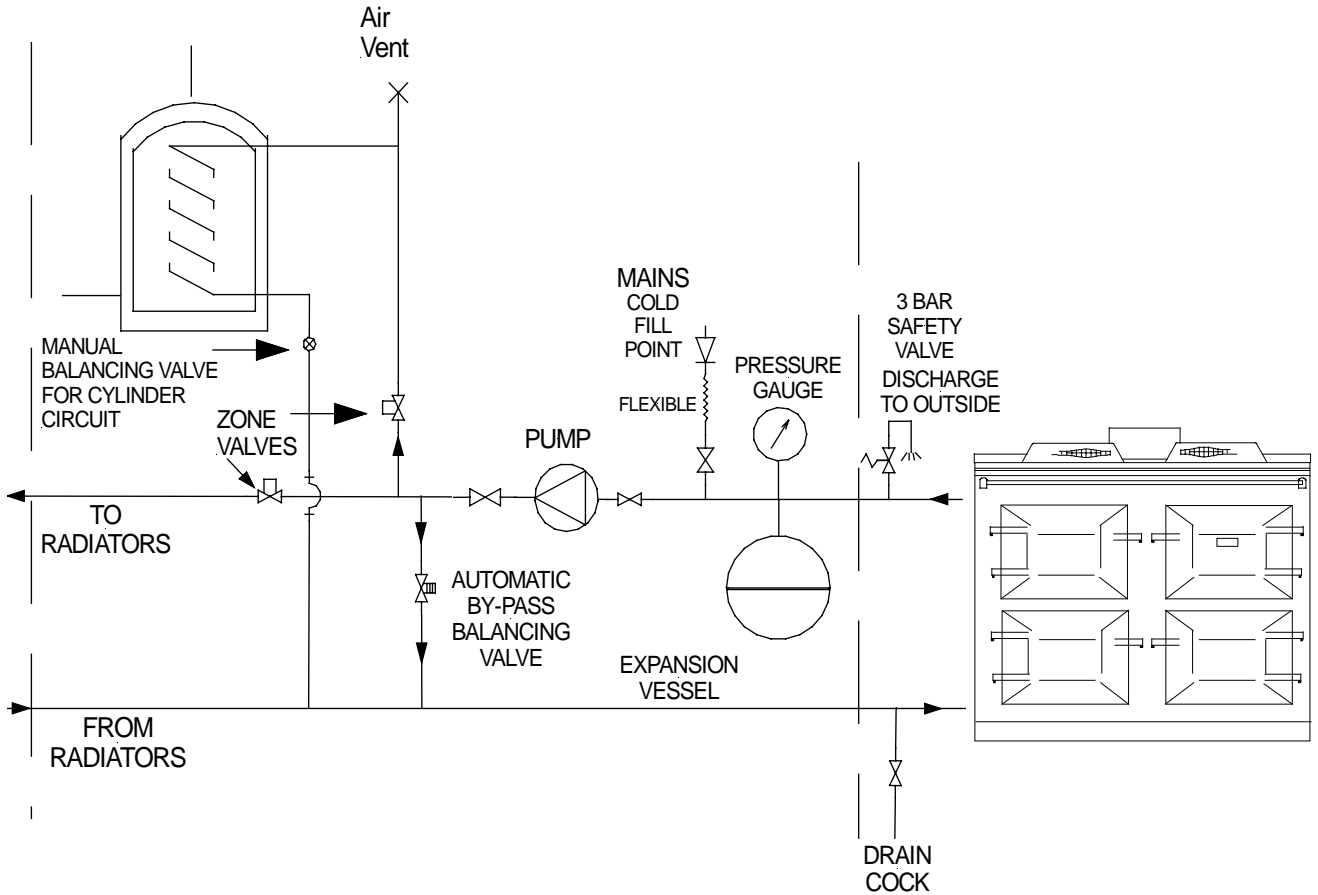

THIS IS A SCHEMATIC SKETCH FOR GUIDANCE ONLY

All installation works must be undertaken by a qualified installer.

Good plumbing practise must be followed at all times.

Not to scale – positions drawn are not accurate.

Pipe sizes are important for satisfactory performance and safety.

Cylinder and expansion vessel capacity must be adequate for system / property

Heating system circulatory pump – The pump must be capable of displacing the heating circuit water for the given output of the boiler.

Your Heritage Range must be compatible with the output required by the heating system.

Account must be taken of domestic hot water requirement, radiator sizes, location and pipe losses. This value must not exceed 95% of the boiler output capacity when calculated at an outside temperature of -1°C and a minimum radiator demand of not less than 50% of the boiler output capacity.

FLUE SYSTEM

Correct and proper installation of the flue system is essential for the safe, efficient and proper running of your Heritage. Please comply with all relevant regulations:

- BS5410: pt 1 - BS 6461: pt 2 - BS 7566: pts 1/4

Do not install your Heritage into a flue serving another appliance.

Do not install your Heritage into a flue which is known to be problematic or may not be suitable for this application. Seek professional advice. A flue draught of between 0.04" & 0.08" WG is required on a cold flue.

Do not construct a flue of single skin pipe for external installation; this will result in excessive condensation (use suitable twin-walled insulated pipe systems). In certain cases, due to geographical and/or barometric factors, an external twin-walled flue may cause a nuisance oven condensation when oven is rising from a temperature below dew point; if possible, flue internally or use the fan flue option.

Whenever a flexible liner is used, it must be the same diameter as the outlet on the Heritage. Flexible flue liners must be of 125mm/150mm diameter and correctly installed. Fabricated flue systems must be Class 3 or Class 1.

HERITAGE CANNOT ACCEPT RESPONSIBILITY FOR AN INCORRECTLY FLUED APPLIANCE.

FLUE TERMINALS

Pressure jet appliances operate under positive pressure. Due to particular weather conditions, down draughts or excessive suction can be experienced. The flue requires an anti down draught cowl to stabilize it and also protect it from ingress of rain or birds!

If using salt glazed clay liners, it is imperative the liners are properly jointed, sealed and flaunched. In some cases clay liners are unsuitable and require a flexible liner.

FLUE HEIGHT

No less than 4 meters (15 feet). The terminal should extend 1 metre above the ridge. See p13.

FAN FLUES

In cases where the only option is low-level discharge, a fan flue must be fitted. However, the application must satisfy your dealer with regard to wind conditions and adjacent features/obstructions. The manufacturers of Heritage Range cookers will accept no responsibility for an appliance or fan assembly subject to damage due to wind backpressure or incorrect installation. Vertical and horizontal fan options are available. At all times be advised by your dealer, **AS STRONG WIND PRESSURE OR DOWN DRAUGHTS CAN DAMAGE YOUR APPLIANCE. THE FAN ASSEMBLY IS CONSTANT RUNNING TO ENSURE THE FLUE SYSTEM IS DYNAMIC AT ALL TIMES – THIS ENSURES FIRE UP EVEN ON VERY COLD START UPS. UNDER NO CIRCUMSTANCES MUST THIS CONFIGURATION BE ALTERED, TO DO SO WILL INVALIDATE YOUR WARRANTY. SEE FAN FLUE TECHNICAL BULLETIN.**

IT IS IMPORTANT WHEN FITTING A FAN FLUE TO ENSURE THE AIR INTAKE (S) IS AS REMOTE FROM THE POINT OF EXHAUST AS IS PRACTICAL, I.E. EITHER TO THE LEFT OR RIGHT OF THE FAN CENTRE LINE BY 1500MM.

TYPICAL FLUE ARRANGEMENTS

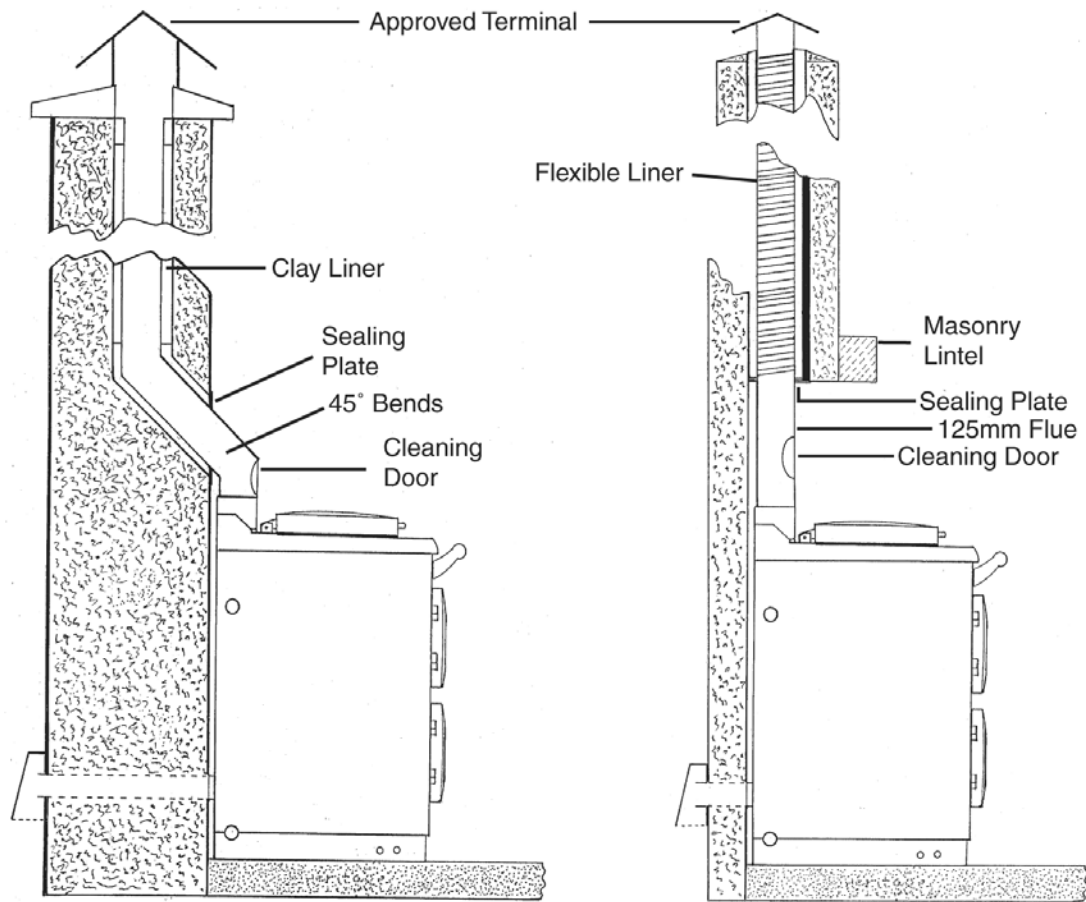

NB: In rare cases clay-lined chimneys may cause condensation, a flexible liner may be required. Seek professional advice.

All models up to and including the 100,000 BTUs model are 5" (125mm) diameter chimney; the larger outputs may require a 6" (150mm) diameter chimney. The flue collar is 5" diameter in all cookers and would need to be adapted.

LOW LEVEL DISCHARGE DIAGRAM.

SECTION ONE - OIL FIRED BOILER INSTALLATIONS

Clearances advised by the Building Regulations for Balanced and Low Level Discharge Flues fitted to Oil Fired Boilers

(see drawing 1.5 for clearances advised by the British Standard)

Drawing 1.4

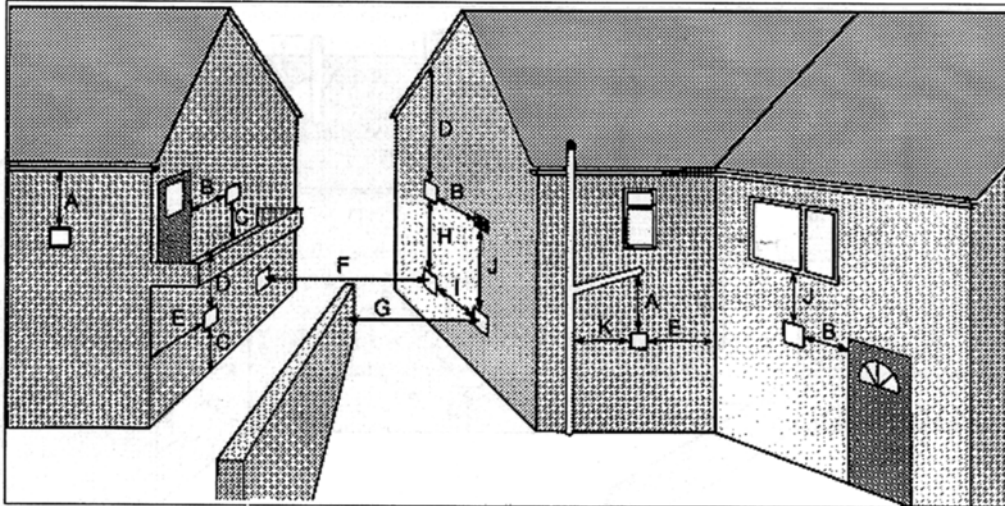

- | | | | |
|----------|--|----------|--|
| A | Below a gutter or sanitary pipework | G | From a surface facing the terminal |
| B | Horizontal from opening, airbrick, window etc. | H | Vertical from terminals on the same wall |
| C | Above ground or balcony level | I | Horizontal from terminals on the same wall |
| D | Below eaves or balcony | J | Below an opening, airbrick, window etc. |
| E | From an internal or external corner | K | From vertical sanitary pipework |
| F | From a terminal facing a terminal | | |

	A	B	C	D	E	F	G	H	I	J	K
Building Regulations											
England and Wales 1991	-	600	-	-	600	-	-	-	-	600	-
Scotland 1990 Balanced*	600	-	600	600	600	600	600	1500	600	600	600
Low level*	1000	-	600	1000	600	600	600	1500	600	600	1000
Northern Ireland 1990	-	600	-	-	600	-	-	-	-	600	-
Republic of Ireland 1991	-	600	-	-	600	-	-	-	-	600	-

NB: Some dimensions & clearances are under review in 2000.



Reproduced by kind permission of OFTEC

OIL SUPPLY AND INSTALLATION

A storage tank installation should meet BS5420.

For a plastic tank install to BS799.pt 1 and for a tank of mild steel install to Oftec Std OFS T100. Ensure the tank is properly supported and maintained. Supply line from tank should be copper and copper fittings ONLY - DO NOT USE GALVANIZED MATERIALS.

All joints must be tight and only oil resisting jointing compounds and PTFE tape used.

Piping must be protected from damage even when under ground.

The size and configuration of piping will be largely dependent on the site conditions and distances between tank and appliance.

Prior to entry into property a suitable fuel safety shut-off valve must be fitted and the sensor must be placed below the boiler burner. For Duettes it is recommended to use a 65°C valve in combination with a fusible valve adjacent to appliance.

We recommend that oil tanks are positioned at least 300mm above the level of the burner. Where the head of oil is negative i.e. oil level is below the level of the burner or in cases where there may be another appliance on same supply line. It may be necessary to install a non-return valve in the oil line.

NB: See burner manual

OIL SUPPLY SKETCHES

(i) Single pipe installation

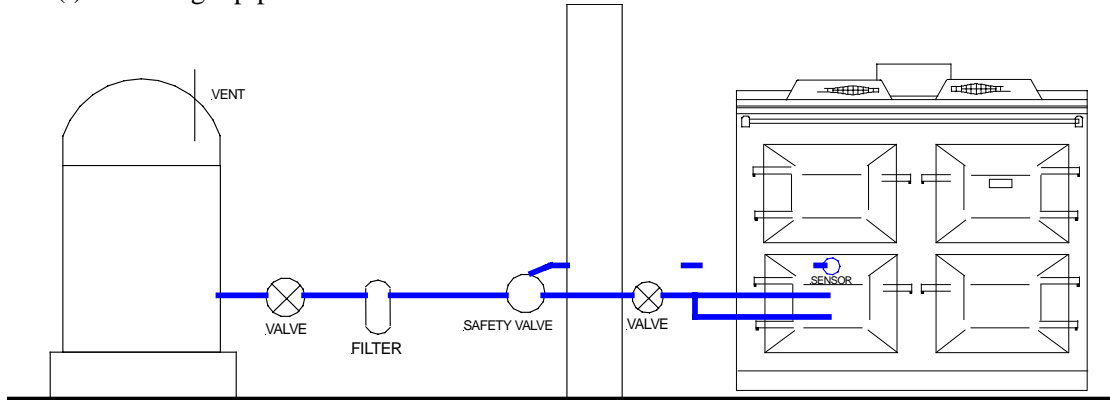

(ii) Tiger loop installation

NB: Horse-shoe washer must be removed from burner. See manual

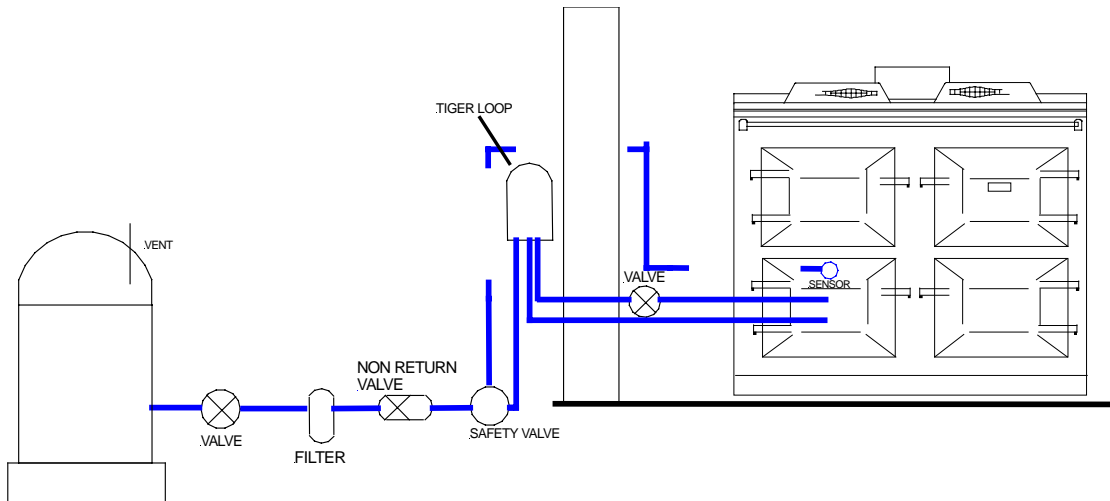

(iii) Two pipe. Supply tank below level of burner. See burner manual

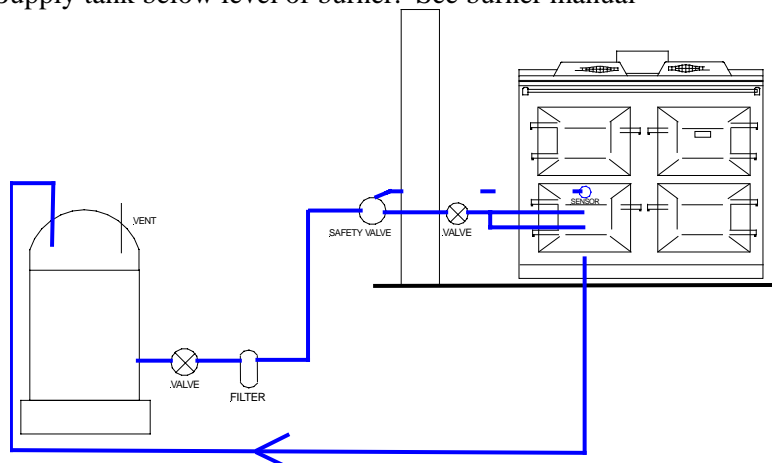

ELECTRICAL SYSTEM

The Heritage Duette Range requires a 230-240v 50Hz supply from a double pole fused spur in accordance with electrical regulations.

The system controls are wired according to the wiring diagram on pages 18 and 19. The schematics are for guidance only; if installing into an existing installation modify the system accordingly.

In installations where voltage spikes occur or supply is known to be variable, please seek professional advice. Failure to do so may result in damage to the appliance or installation and could void your warranty.

The schematic diagram of appliance internal wiring is shown on page 17. The 7-pin plug to connect to external wiring shown on page 18/19 is provided for your convenience with the Heritage Duette Range cooker.

Earthing arrangements must comply with BS7671 and/or local Electricity Suppliers rules for PME.

NB. Do not alter internal wiring or connect to internal wiring (page 17) except via the appliance plug/system plug (page 18/19).

ELECTRICAL INTERNAL PANEL WIRING DIAGRAM

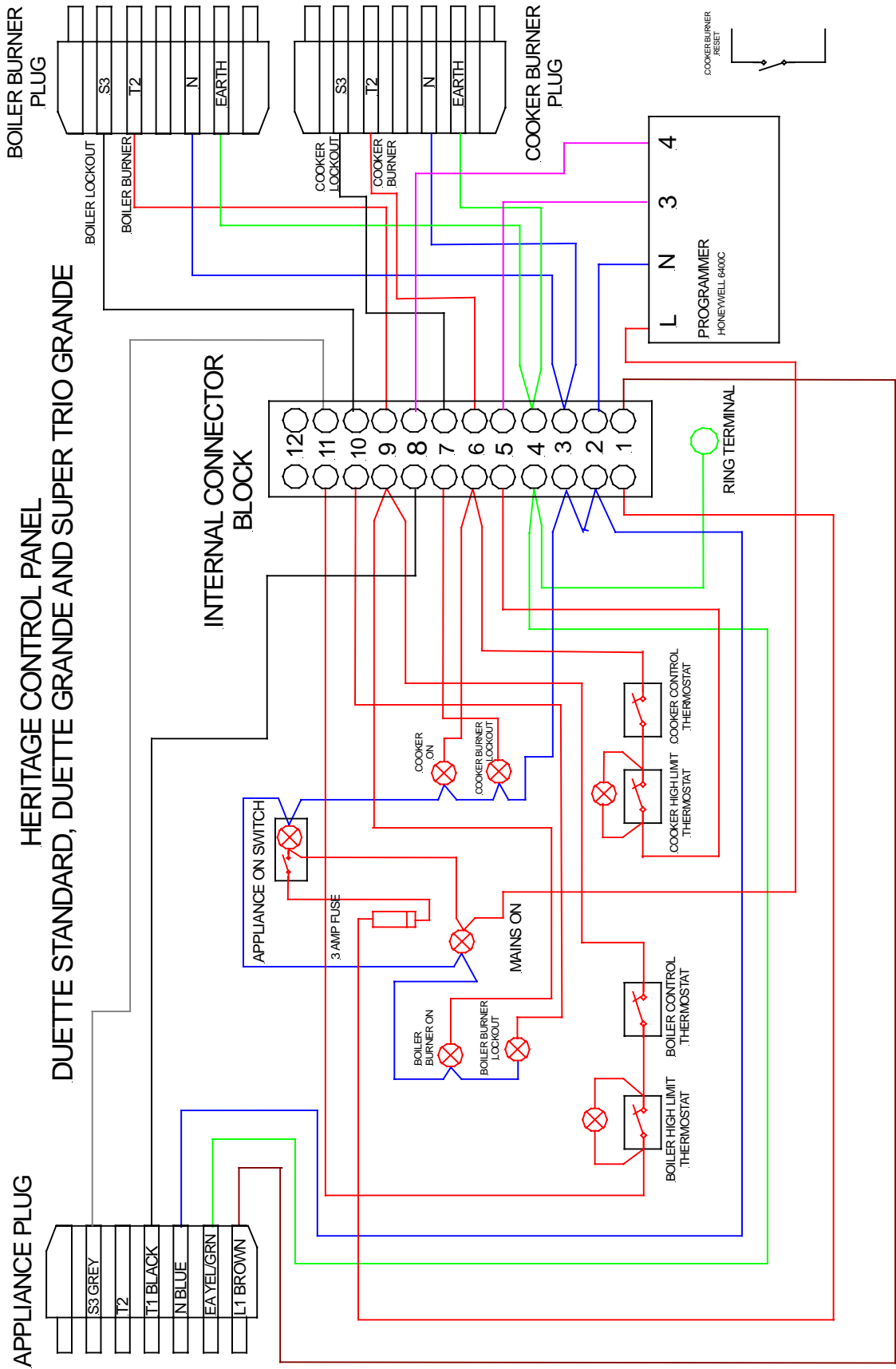

WIRE COLOURS MAY DIFFER FROM DRAWING

05-03-07 ISSUE 1 CORRESPONDING SYSTEM DRAWINGS 05-04-13 & 05-04-13-FF

ELECTRICAL SYSTEM WIRING DIAGRAM

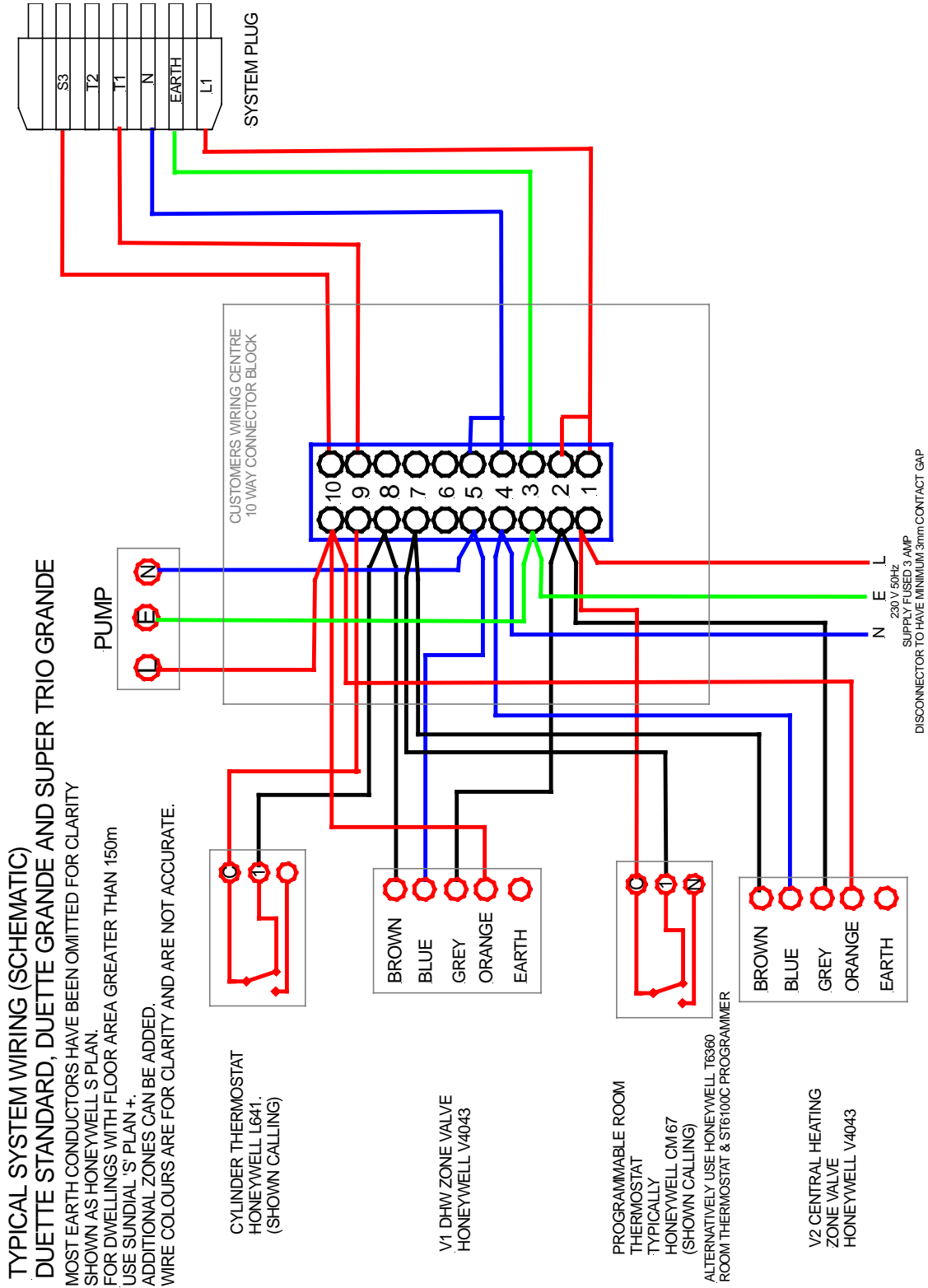

05-04-13 CORRESPONDING PANEL DRAWING 05-04-06

DISCONNECTOR TO HAVE MINIMUM 3mm CONTACT GAP

ELECTRICAL SYSTEM WIRING DIAGRAM FAN FLUE

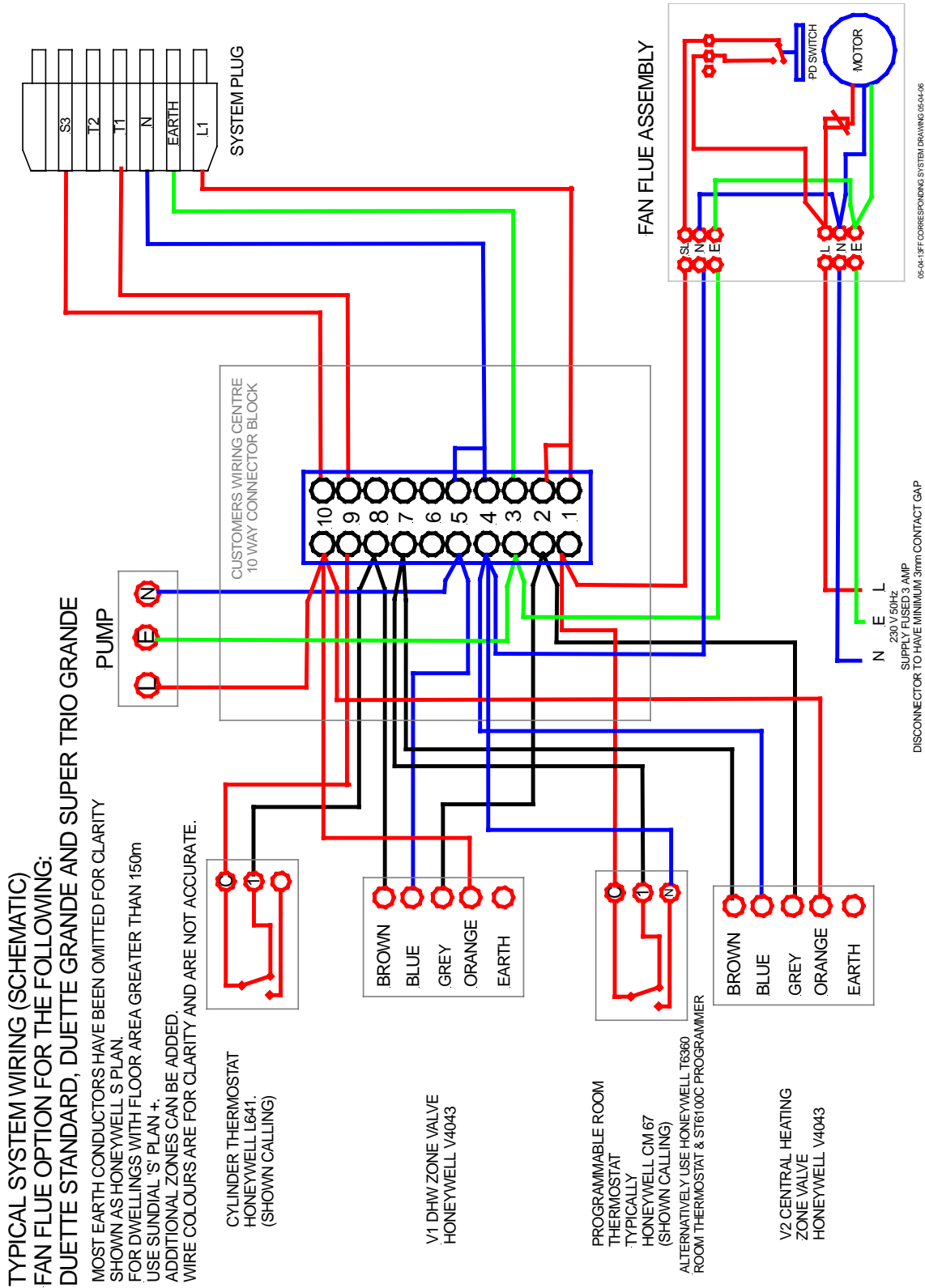

10 WAY CONNECTOR EXPLANATION CHART

- 1) Mains live from 3-amp double pole fused spur / Fan flue supply
- 1) Live feed to programmable thermostat

- 2) Grey from hot water + heating zone valves

- 3) All earth connections

- 4) Neutrals from C/H zone valve + Fan flue if used

- 5) Neutrals from circulating pump + DHW zone valve

- 6) Spare

- 7) Live to brown on C/H valve
- 7) Live to no.1 on programmable room thermostat

- 8) Live to brown on DHW valve
- 8) Live from no.1 on cylinder stat.

- 9) Live to common on cylinder stat.

- 10) Live from orange on both hot water and heating zone valves
- 10) Live to pump

COMMISSIONING PROCEDURE

Your Heritage Duette Range MUST be commissioned by a competent OFTEC-qualified engineer or a Heritage-trained engineer.

UNDER NO CIRCUMSTANCES SHOULD YOUR HERITAGE DUETTE RANGE BE FIRED PRIOR TO COMMISSIONING - To do so may cause damage to the unit and may void your warranty.

The system should be commissioned by your qualified OFTEC installer.

PARTICULAR ATTENTION SHOULD BE PAID TO THE FOLLOWING:-

GENERAL SYSTEM

- Position of Appliance with respect to combustible materials
- Pipe work - size and design
- Heat dissipating circuit and auto by-pass valve
- Operation of controls/pump
- Chimney suitability - flue draught/terminal*
- Permanent air ventilation
- Oil supply remote acting fire valve, isolation valve, filter
- Electrical installation. Is the isolation switch operable?
- Cylinder/Size & plumbing/heating installation.
- Safety valve, overflow installation
- Has the system been flushed **and filled with inhibitor**
- Tank/Oil - Position of tank - correct grade oil 28-35 sec

Only if the above parameters are correct should the appliance burners be set up and fired. (Your engineer should telephone the supplier if there are any doubts). Heritage reserve the right to condemn an installation prior to commissioning – A charge will be made and a revisit will be required to validate warranty.

Ensure oil line is purged to bulkhead connection on the plinth.

LIFT left hand hot plate cover before starting from cold. (See p 27 - Operating Instructions).

Switch on mains supply - the green neon will illuminate. Set programmer sliders to continuous. Turn boiler control thermostat knob to between min & 2, the green neon will illuminate showing power to boiler burner - burner will begin it's pre-purge cycle and fire-up - if burner locks out as shown by amber light ON, allow 1 minute to reset and then press reset button on burner control box. Prime pump purge of air if necessary.

NB: Purge through oil pump bleed screw.

Switch cooker on (large green rocker switch) and repeat same procedure for cooker burner - should this burner go to lock out there is a remote manual reset button located adjacent to programmer, press once, burner should fire. If burner doesn't fire, remove fixing screws from control panel and purge burner of air as before. When running correctly replace panel.

COMMISSIONING PROCEDURE (continued)

Set programmers and observe the operation of burners through the control of programmer and thermostats.

Due to the nature of the materials used in its construction the Heritage Range will initially produce some odours of curing ceramics and oils/lubricants - please advise the householder that this is normal and will be short lived. - Allow adequate ventilation.

NB: At this point check appliance/flue/chimney for satisfactory containment of flue gases and operation.

*Flue conditions draught will vary with weather conditions. After the engineer has left

should the appliance performance change (e.g. noise level, smells or fumes) please contact the installer immediately after switching off the appliance.

Remove grub screws from flue spigot and check flue gas analysis throughout the following sequence. (Replace screw on satisfactory completion of analysis).

FOR BOILER mode typical gas readings are: -

CO₂ = 9.0 – 10.5%

CO = < 50ppm

O₂ = 4 - 6%

FLUE TEMP = 135 - 200°c

NETT COMBUSTION EFFICIENCY = 88 - 90%

Open bottom left hand door, remove finishing panel, to access boiler burner.

Each burner is factory preset and tested. The boiler burner is set at an air setting to match output (see data plate inside door of Range) and 130 psi pump pressure.

If required adjust the air setting as described in burner manual. Flue conditions will affect these settings. If the CO level is above 50 ppm, but falling, this is due to the binders and lubricants burning in the combustion chamber, allow more time to settle. Typically 1 hour.

FOR COOKER mode please see data plate inside door of Range.

To access oven burner open control door, remove control panel.

The cooker burner is set at **5** air and **115** psi pump pressure*.

When gas analysis is complete, record data for future reference.

OBSERVE CORRECT PRACTICE FOR ELECTRICAL SAFETY. WHEN WORKS ARE FINISHED REPLACE ALL COMPONENTS AND SECURELY REPLACE PANEL.

Properly instruct the customer on the use of the appliance.

Leave the manual and a contact telephone number with the customer.

***The cooker burner MUST be set as above.**

FAULT FINDING

The Heritage Duette Range has no internal moving components and is by design an extremely simple and robust appliance. Given that your Heritage Range has been installed to the guidelines in this manual and that it has been operated correctly, from time to time 'faults' or nuisance problems may arise. The majority of these will be very easily diagnosed and rectified. The following list assumes the Programmer is on 'CONTINUOUS' or on override (where relevant).

SYMPTOM	PROBABLE CAUSE	ACTION
<u>Burner</u>		
Burners will not fire	Mains supply	Check
	Fuel supply	Check, fill if required
	Burner lock-out	Reset
	High Temperature lockout	Reset/Check system
Burners run but lock out*	Fuel Supply Ignition (burner)	Check, fill if required Call Engineer
Burners fire for short interval then stop	Flue Problem Fuel contamination	Inspect flue ways Call Engineer
<u>Operational Problems</u>		
Oven not Heating	Burner faulty	Check/replace
	Programmer setting, incorrect	Check/reprogramme
	Stats faulty	Check/replace
Radiators not heating	Burner faulty	Check/replace
	Pump not running	Check/replace
	Air in system	Purge system
	Heat load too high	Switch off some rads^
	Programmer/setting	Check/re-programme
	2-way valve/faulty	Check/replace

***DO NOT ATTEMPT TO RESET LOCK OUT BUTTON MORE THAN 3 TIMES WITHOUT CONTACTING YOUR ENGINEER**

^ This will prove diagnosis - refer to engineer/installer

FAULT FINDING (continued)

SYMPTOM	PROBABLE CAUSE	ACTION
Domestic hot water not heating	Faulty cylinder stat	Check/replace
	Air lock/Air in system	Check/bleed
	Cylinder stat too low	Increase setting
	Pump not working	Check/replace
	Boiler stat too low	Alter settings
	Programmer faulty/Setting	Check/re-programme
	2-way valve fault	Check/replace
Rusty Domestic hot water	Domestic plumbing problem	Call installer
Oven not reaching set temperature	Oven stat set too low	Set at Max.
	Oven stat faulty	Call installer
Persistent condensation in ovens	Insufficient flue draught	Call installer
	Possible partial blockage of flue	Call installer

(NB occasional condensation may occur during firing from cold or with some open pan cooking.)

It is common for 'ticking' noises to come from your Heritage Duette Range whilst it is heating up or cooling down. However, if you should experience banging noises, switch off the appliance and call your installer.

In the event of a problem that cannot be readily resolved, please telephone your installer and/or dealer quoting your appliance serial number.

SERVICING AND MAINTENANCE

28-sec Kerosene

It is imperative that your Heritage Duette Range be serviced by a qualified engineer at least once a year.

35-sec Kerosene (& commercial use of cooker)

NB. Please ensure cooker and boiler burners are serviced twice a year.

Bio-fuels

DO NOT USE BIO FUELS WITHOUT FIRST OBTAINING WRITTEN AUTHORISATION FROM HERITAGE RANGE COOKERS

The unit should be recommissioned after servicing.

Servicing

This does not involve external cleaning of appliance, replacement of seals, gaskets to door etc., unless otherwise agreed at extra cost.

Please see supplied Service Guide & page 26 for guidance. If you have any doubts please contact your supplier.

NB Please keep a record of all Service visits – see page 30.

Guarantee & Warranty

Your Heritage is built to very exacting standards by a dedicated team of craftsmen and we anticipate that you should enjoy many years of faithful service.

As testimony to the confidence we have in our product we offer 1 year's full warranty on parts and labour. We also offer a full 3 years cover on the boiler, combustion chamber and oven/flue assembly. This warranty is based on the assumption that the appliance has been installed, operated and maintained in accordance with the guidelines of this manual.

NB: It is essential to forward a copy of your OFTEC commissioning certificate to the manufacturer (Heritage Range Cookers), within 14 days of commissioning to register your warranty.

We want your Heritage Duette Range to last.

FOR EXCLUSIONS & CONDITIONS PLEASE SEE PAGE 2.

DAMAGES TO ENAMEL AND DECORATIVE FINISHES ARE NOT COVERED BY WARRANTY OR GUARANTEE.

HERITAGE SERVICE SHEET

Servicing procedure for both Standard & Compact Duette Range Cookers

Servicing the Heritage Range is a relatively straightforward procedure. The cooker has been designed to be an engineer-friendly appliance. Included within these instructions are the items we recommend to change every service.

As with all oil-fired units the servicing engineer must be OFTEC qualified and be competent to undertake the following work.

Please check that the external air supply pipes are UN-obstructed and are positioned as per the installation manual.

- 1) Isolate power supply to unit
- 2) Remove control panel and inspect all wiring is secure and correct on the control panel
- 3) Split Cooker burner & check all components including the oil line are in a satisfactory condition. We suggest the nozzle is always replaced as a matter of course (.30x60°)
- 4) Remove second part of burner allowing you to inspect both blast tube and combustion box, check condition of ceramics. Refit with new supplied gasket.
- 5) Remove boiler burner and carry out the same work as at 3) above. The boiler burner nozzle must be replaced with the correct sized item as stated by Heritage cookers ie.data plate.
If there are any indications of the burner producing soot then the burner body must be removed and the boiler ceramics checked. Refit with new supplied gasket.
- 6) Once the burners are re-fitted the power supply can be reconnected ready for the recommissioning.
- 7) The burners must be recommissioned to the following. Cooker burner **MUST** always be set at **115psi** pump pressure and **5** on the burner air setting screw. These figures may give slightly different analization readings than you would anticipate. The Boiler burner pump pressure will be **135psi** but your air setting will depend on the Boiler output. You are looking to achieve a CO2 reading of no more than 10.5%. This should allow a PPM figure of less than 50ppm. Please refer to data plate on the unit.
- 8) Refit control panel and run the water system and ovens up to temperature.
NB Check control stats are operating throughout their range.

Please do not hesitate to contact Heritage Range Cookers if there are any queries with the above.

OPERATING INSTRUCTIONS

USING YOUR HERITAGE DUETTE RANGE

Your Heritage Duette Range and system have been commissioned and you are now ready to experience your Heritage!

During heating of oven from cold **LIFT LEFT-HAND HOT PLATE COVER** to reduce temperature of hot plate & cover. At all other times the covers can be left in any position.

The Grande model also has a baffle that allows the unit to be operated as a 2-oven or 4-oven range. The baffle is controlled by a lever positioned at the top of the control panel [lever to left = baffle open (4-oven); lever to right = baffle closed (2-oven)]. The adjustment **MUST** be made from cold to allow a prolonged firing period, which enables the left-hand ovens to reach temperature. Reducing to the 2-oven mode is fine if full cooking capacity is not required.

DO NOT COOK WITH BAFFLE IN MID-POSITION (Grande models only).

On opening the control door you will see the control panel, consisting of knobs and neon lights. The green “Mains” neon should be on, indicating mains supply.

Move both programmer sliders to “continuous”, turn the boiler stat to between Min & 2, and the oven stat to the desired temperature. The burners will now fire, and you have total use of your hot plates, ovens and hot water.

We recommend you acquaint yourself with the function of these basic controls before you start using the in-built programmer.

The ideal setting for the boiler thermostat is between Min & 2 (the thermostat controls the boiler temperature not your domestic hot water temperature). The thermostat on your cylinder controls hot water temperature. By utilising the built-in programmer, it is possible to store domestic hot water all day long with great efficiency.

Enjoying your Central Heating is all part of the Heritage experience; by simply setting the programmable room thermostat to your requirements the Heritage will respond and operate the heating system independently from its other functions – even when the cooker is off.

To manually shut down your Duette please use the following procedure:- Position both programmer sliders to the **OFF** position & set both control knobs to **MIN**.

OPERATING INSTRUCTIONS (continued)

COOKING

If you have never used a Range cooker before owning your Heritage Duette Range, you will need to allow yourself time to become acquainted with the methods of use.

When programming your Heritage to come on during hot weather, please do not allow foods to remain at temperatures that could result in bacterial contamination. Always defrost foodstuffs thoroughly prior to cooking.

A Heritage Cooking Guide is enclosed but this is not meant to replace a Range Cookbook.

MAIN OVEN (top right). This oven is hotter towards the top than bottom.

NB Turn your cooking tray around approximately halfway through the cooking period for best results.

DO NOT operate your cooker with the top oven door open - this bypasses the controls and will cause damage to your appliance.

The left hand lid should be left in the upright position for 30 minutes when starting to heat the ovens from cold.

HERITAGE CONTROL PANEL

- Legend:
- A = Mains power indicator (green)
 - B = 3 A Fuse (spare taped to panel-keep safe)
 - C = Cooker ON/OFF switch
 - D = Boiler Burner ON (green)
 - E = Boiler Burner lockout (amber)
 - F = Boiler high limit (red)
 - G = Oven burner ON (green)
 - H = Oven burner lockout (amber)
 - I = Oven high limit (red)

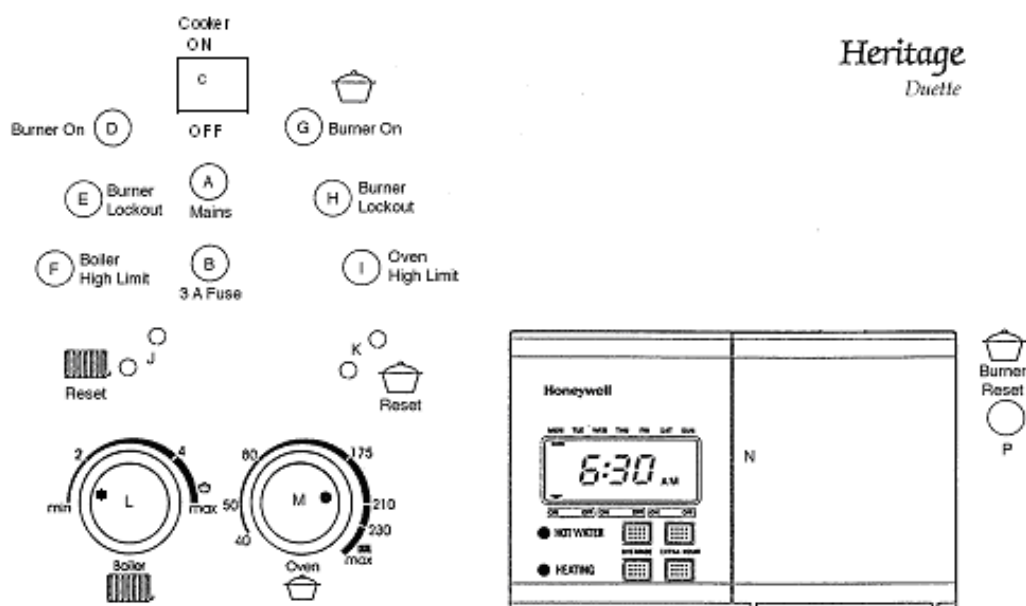

- J = Boiler high limit reset (press red button)
- K = Oven high limit reset (press red button)
- L = Boiler control thermostat
- M = Oven control thermostat
- N = In built programmer HWST6400C (instructions provided)
- P = Oven burner lockout reset (press once)

PROGRAMMER

Please see Honeywell manual enclosed with this manual.

LOOKING AFTER YOUR HERITAGE

Your Heritage is finished in a lustrous vitreous enamel. Enamel is a very robust finish, but care must be taken to protect it.

- a) Do not leave heavy objects, which might chip or scratch the enamel on the top plate.
- b) Avoid striking the enamel with hard objects.
- c) Daily wipe cooker with a soapy damp cloth and polish up with a duster. Do not do this if the appliance is hot.
- d) Always wipe off spillages as they happen using a moist cloth. The top plate is acid resistant, however always wipe off fruit juices, milk etc., especially if cooker is warm. Do not put a wet cloth on hot enamel.
- e) Use an approved cream cleanser when required - look for the VEDC mark.
- f) Never use abrasive cleaners or scouring pads on the enamel,
- g) Food stuffs containing sugars can damage enamel - wipe off immediately.
- h) Never use a chip pan or similar utensil on your Heritage unattended. Should the oil boil over it would seep into the insulation and would present a fire hazard.

Care of hot plates and ovens

The hot plates are of chrome steel, whilst shiny when new, they will dull in use, but will not rust. They can be cleaned using a suede brush or steel wool, then polished with either vegetable oil or olive oil. Do not use too much oil as this will seep into the insulation and may become a hazard. To clean ovens turn up to max temperature and deposits will be carburised. Only use quality oven cleaning agents. Re-oil ovens to seal them.

The surface texture of your enamel finish is largely due to the nature of cast iron and steel. Some unevenness of the finish may be evident; this is not a flaw but a characteristic of cast iron and steel. All components used in the assembly to your Heritage Range have been quality checked before leaving our workshops.

NOTES